

OWNER'S MANUAL

ALTERNATING-TREAD STAIR • Series ATS

Contents

Receiving Instructions	1	Specification Drawing	2
Warranty	1	Assembly/Installation Instructions	3
Specification Chart	1		

RECEIVING INSTRUCTIONS

Every unit is thoroughly tested and inspected prior to shipment. However, it is possible that the unit may incur damage during transit. If damage is noticed when unloading, make a note of it on the **BILL OF LADING**. Remove all packing and strapping material, then inspect the unit again for damage. **IF DAMAGE IS EVIDENT, FILE A CLAIM WITH THE CARRIER IMMEDIATELY!**

WARRANTY

This product is warranted for 90 DAYS from date of purchase to be free of manufacturing defects in material and workmanship.

This warranty does not cover normal wear of parts or damage resulting from any of the following: negligent use or misuse of the product, a use or application contrary to installation instructions, or the disassembly, repair or alteration by any person prior to authorization from a factory representative.

SPECIFICATIONS (for Drawing on Back)

Model Number	Number of Steps	Height (A)	Length (B)	Step Height (C)	Angle (D)	Handrail Height (E)	Usable Step Length (F)	Bottom Handrail Height (G)
ATS-4-56	7	48"	36-5/8"	6-7/8"	56°	17-3/16"	9-1/4"	27-1/2"
ATS-5-56	8	60"	44-11/16"	7-1/2"	56°	17-3/16"	10-1/8"	27-1/2"
ATS-6-56	10	72"	52-13/16"	7-3/16"	56°	17-3/16"	9-11/16"	27-1/2"
ATS-7-56	12	84"	60-7/8"	7"	56°	17-3/16"	9-7/16"	27-1/2"
ATS-8-56	13	96"	69"	7-3/8"	56°	17-3/16"	9-15/16"	27-1/2"
ATS-9-56	15	108"	77-1/16"	7-3/16"	56°	17-3/16"	9-11/16"	27-1/2"
ATS-10-56	16	120"	85-3/16"	7-1/2"	56°	17-3/16"	10-1/8"	27-1/2"
ATS-4-68	6	48"	26"	6-7/8"	68°	10-13/16"	5-9/16"	34"
ATS-5-68	7	60"	30-13/16"	7-1/2"	68°	10-13/16"	6-1/16"	34"
ATS-6-68	9	72"	35-11/16"	7-3/16"	68°	10-13/16"	5-13/16"	34"
ATS-7-68	10	84"	40-9/16"	7"	68°	10-13/16"	5-11/16"	34"
ATS-8-68	11	96"	45-3/8"	7-3/8"	68°	10-13/16"	5-15/16"	34"
ATS-9-68	13	108"	50-1/4"	7-3/16"	68°	10-13/16"	5-13/16"	34"
ATS-10-68	14	120"	55-1/16"	7-1/2"	68°	10-13/16"	6-1/16"	34"



**ALTERNATING-TREAD STAIR
 Series ATS**

ENGLISH

ESPAÑOL

FRANÇAIS

SPECIFICATION DRAWING

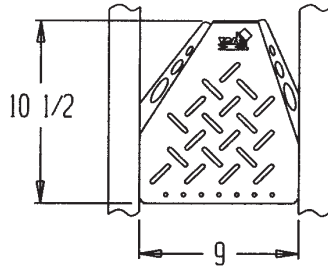
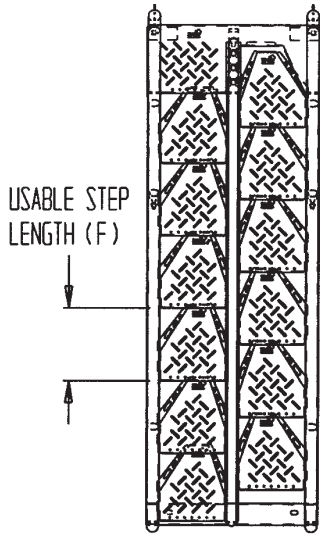

Ø 9/16 X 1
SLOT
2 PLACES

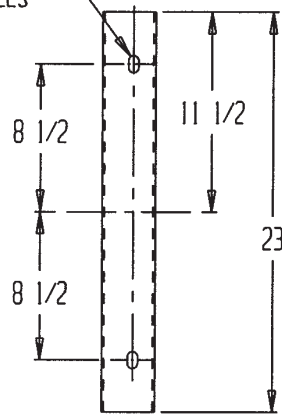

Ø 9/16 X 1
SLOT
2 PLACES

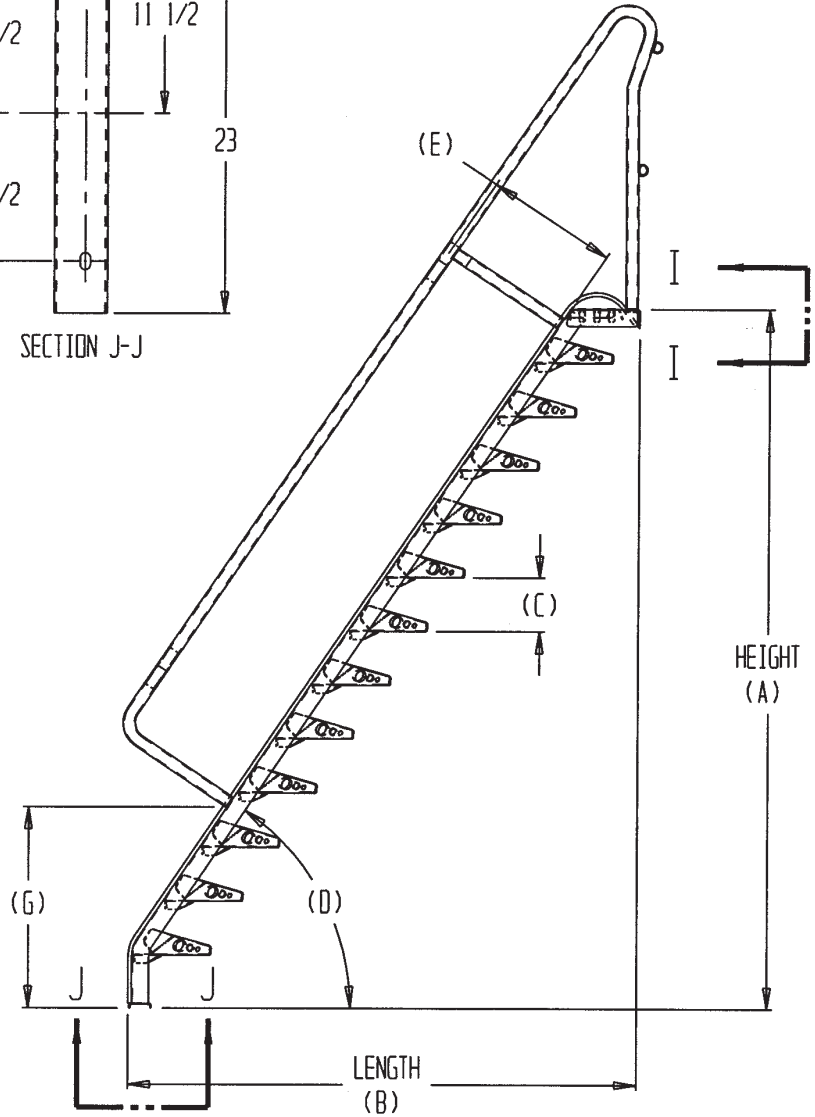
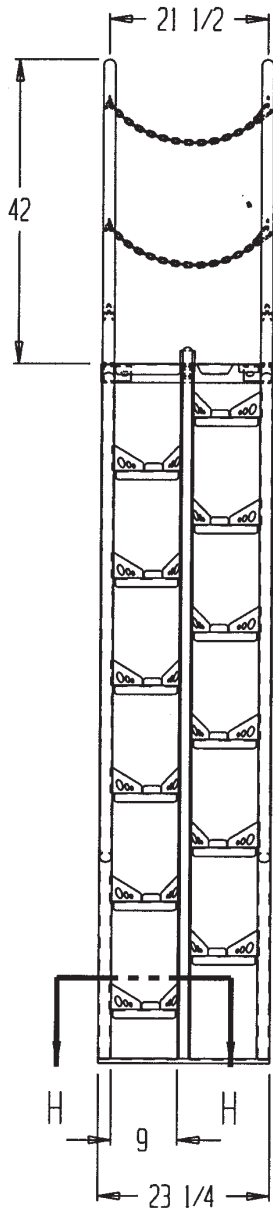
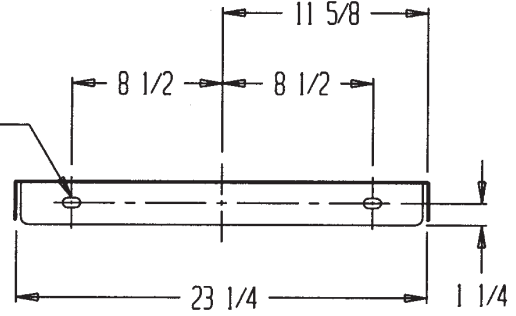

ASSEMBLY / INSTALLATION INSTRUCTIONS

Review this entire page before installing the stair. Consult the factory in the event there are any questions or problems at the time of installation.

- The alternating-tread stair is intended for installations requiring a stair having an angle of inclination of 56° to 68° to the horizon. It has a maximum load capacity of 300 pounds.
- Modifications to the stair without prior manufacturer's authorization may void the stair's warranty.
- The stair must be appropriately anchored at the top and bottom before use.
- The installation must be made so that it complies with all the building regulations applicable to the location. The end-user must verify that the stair is installed so it will be suited for the application in which it will be used.
- Installation must be performed by suitably trained personnel with access to the appropriate equipment.

TOOLS FOR INSTALLATION:

1. A fork truck or hoisting means to unload the lift from the freight truck. It will also be advantageous to have the lifting device to help set the stair into place.
2. Tools and hardware appropriate for the selected method of installation. Consult the building's architect or facility engineer to determine the best type of hardware with which to anchor the stair.

ASSEMBLY:

1. Turn the stair on its side.
2. Secure the lower handrail (consult the included assembly drawing for identification of the handrails) to the lower end of the tread runner using a 1/2" flat washer, lock washer, and bolt.
3. Slide the upper handrail onto the lower handrail.
4. Secure the end of the upper handrail and its support bracket using 1/2" flat washers, lock washers, and bolts.
5. Turn the unit on the opposite side and repeat steps 2 - 4.

INSTALLATION:

1. Stand the stair upright, with the highest step resting against the side of, and the top step even with, the upper floor level.
2. Attach the top of the stair by installing appropriate hardware through the hole and slot located in the edge of the top step.
3. **Warning!** Do not stand on the stair until the installation is complete.
4. Attach the bottom of the stair to the lower floor level using appropriate hardware through the slots in the base channel.
5. Align the bottom and top ends of the stairs so the stair is perpendicular to the wall it is being mounted against, and tighten all hardware wrench-tight.
6. There are snap hooks on the ends of each of the two included safety chains. Attach one end of each chain to a d-ring on one of the upper handrail's vertical posts. Attach the other end of each chain to a d-ring on the opposite post. Keep the chains secured across the top stair opening when the stairs is not being used.

Periodically check that all the stair fasteners are maintained wrench tight.

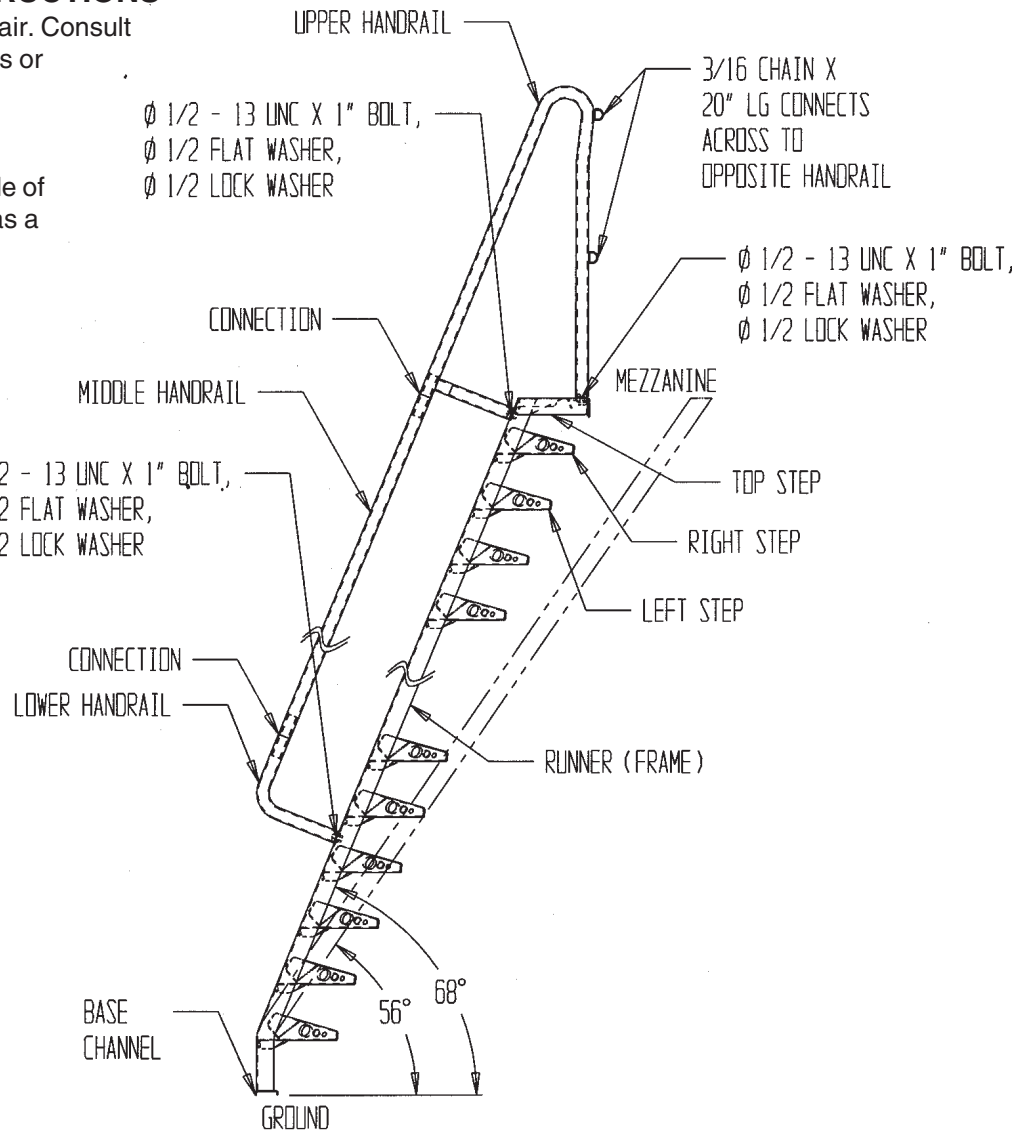

LIMITED WARRANTY

Vestil Manufacturing Corporation (“Vestil”) warrants this product to be free of defects in material and workmanship during the warranty period. *Our warranty obligation is to provide a replacement for a defective original part if the part is covered by the warranty, after we receive a proper request from the warrantee (you) for warranty service.*

Who may request service?

Only a warrantee may request service. *You are a warrantee if* you purchased the product from Vestil or from an authorized distributor AND Vestil has been fully paid.

What is an “original part”?

An original part is a part used to make the product as shipped to the warrantee.

What is a “proper request”?

A request for warranty service is proper if Vestil receives: 1) a photocopy of the Customer Invoice that displays the shipping date; AND 2) a written request for warranty service including your name and phone number. Send requests by any of the following methods:

Mail
Vestil Manufacturing Corporation
2999 North Wayne Street, PO Box 507
Angola, IN 46703

Fax
(260) 665-1339
Phone
(260) 665-7586

Email
sales@vestil.com

In the written request, list the parts believed to be defective and include the address where replacements should be delivered.

What is covered under the warranty?

After Vestil receives your request for warranty service, an authorized representative will contact you to determine whether your claim is covered by the warranty. Before providing warranty service, Vestil may require you to send the entire product, or just the defective part or parts, to its facility in Angola, IN. The warranty covers defects in the following *original* dynamic components: motors, hydraulic pumps, electronic controllers, switches and cylinders. It also covers defects in *original* parts that wear under normal usage conditions (“wearing parts”): bearings, hoses, wheels, seals, brushes, batteries, and the battery charger.

How long is the warranty period?

The warranty period for original components is 90 days. The warranty period begins on the date when Vestil ships the product to the warrantee. If the product was purchased from an authorized distributor, the period begins when the distributor ships the product. Vestil may extend the warranty period for products shipped from authorized distributors by *up to* 30 days to account for shipping time.

If a defective part is covered by the warranty, what will Vestil do to correct the problem?

Vestil will provide an appropriate replacement for any *covered* part. An authorized representative of Vestil will contact you to discuss your claim.

What is not covered by the warranty?

1. Labor;
2. Freight;
3. Occurrence of any of the following, which automatically voids the warranty:
 - Product misuse;
 - Negligent operation or repair;
 - Corrosion or use in corrosive environments;
 - Inadequate or improper maintenance;
 - Damage sustained during shipping;
 - Collisions or other incidental contacts causing damage to the product;
 - Unauthorized modifications: DO NOT modify the product IN ANY WAY without first receiving written authorization from Vestil. Modification(s) might make the product unsafe to use or might cause excessive and/or abnormal wear.

Do any other warranties apply to the product?

Vestil Manufacturing Corp. makes no other express warranties. All implied warranties are disclaimed to the extent allowed by law. Any implied warranty not disclaimed is limited in scope to the terms of this Limited Warranty.

